

Pump Model CPS 300-250-370

Speed 1450rpm

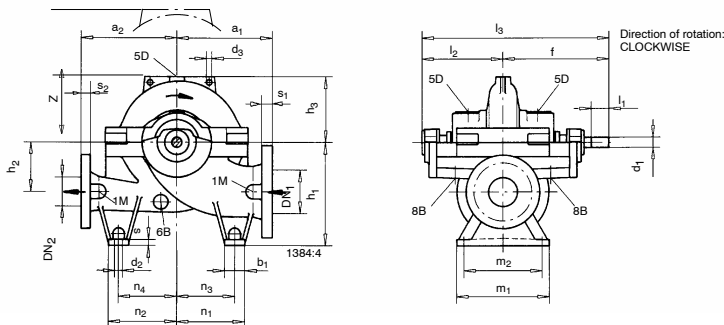
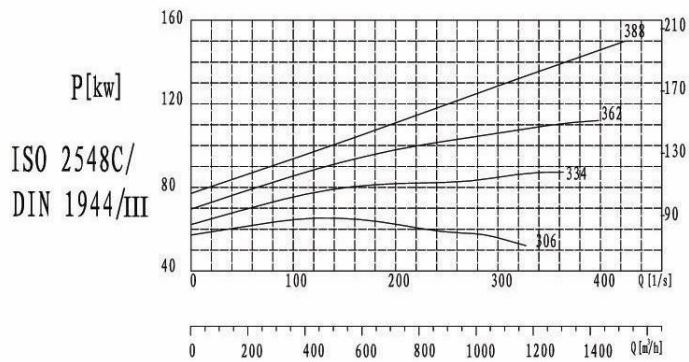
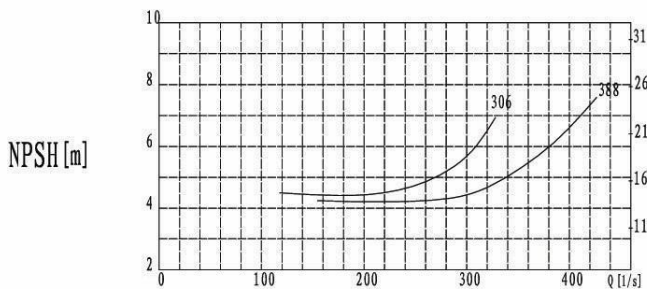
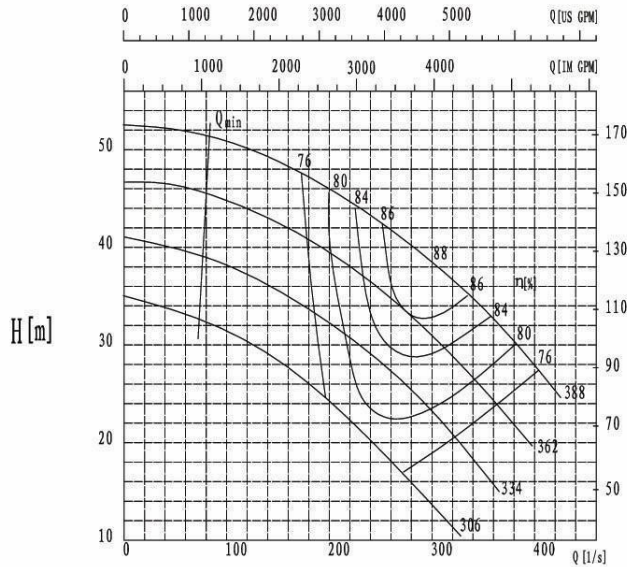

Pump Size	FLANGE DIMENSIONS				PUMP DIMENSIONS									
	DN1	DN2	s1	s2	a1	a2	d3	f	h1	h2	h3	l2	l3	z
CPS 300-250-370	300	250	33.4	32	500	500	12.5	655	600	300	320	464	1119	640
	FOOT DIMENSIONS					SHAFT					PUMP WEIGHT			
	b1	d2	m1	m2	n1	n2	n3	n4	s	d1	L1	(kg)		
100	22	480	400	400	400	350	350	26	65	140	665			